

" TABLE 부착 " - 옵션 사양

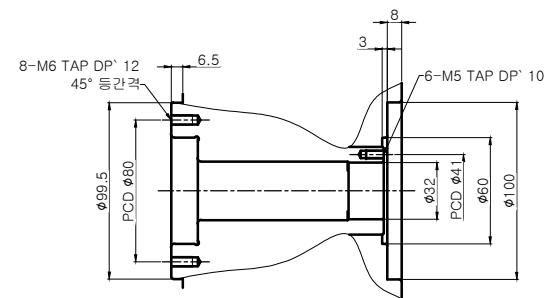

" TABLE 미부착 " - 표준

[ TR-120YY Specifications ]

A축 사양 (경사)		C축 사양 (회전)	
Tilting Angle	+110° ~ -20°	Rotating Angle	360°
Clamp Force	300 N.m	CLAMP FORCE	200 N.m
Clamp Method	HYD. (Max 2.5MPa)	Clamp Method	HYD. (Max 2.5MPa)
Gear Ratio	1 / 180	Gear Ratio	1 / 90
Max. RPM	16.6 (Motor 3000 min <sup>-1</sup> )	Max. RPM	33.3 (Motor 3000 min <sup>-1</sup> )
Servo Motor	SGM7J-08A7A6S	Servo Motor	SGM7J-08A7A6S
HYD. Port	적용되지 않음	Work Weight (kgf)	35

Weight : 115 kgf

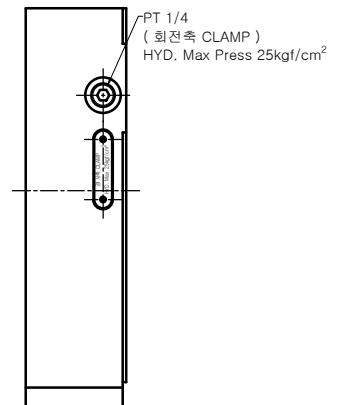
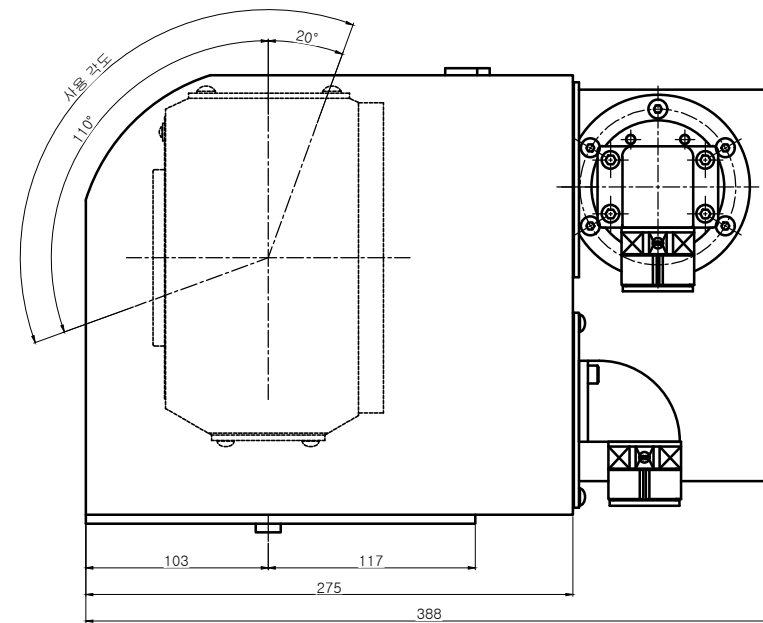
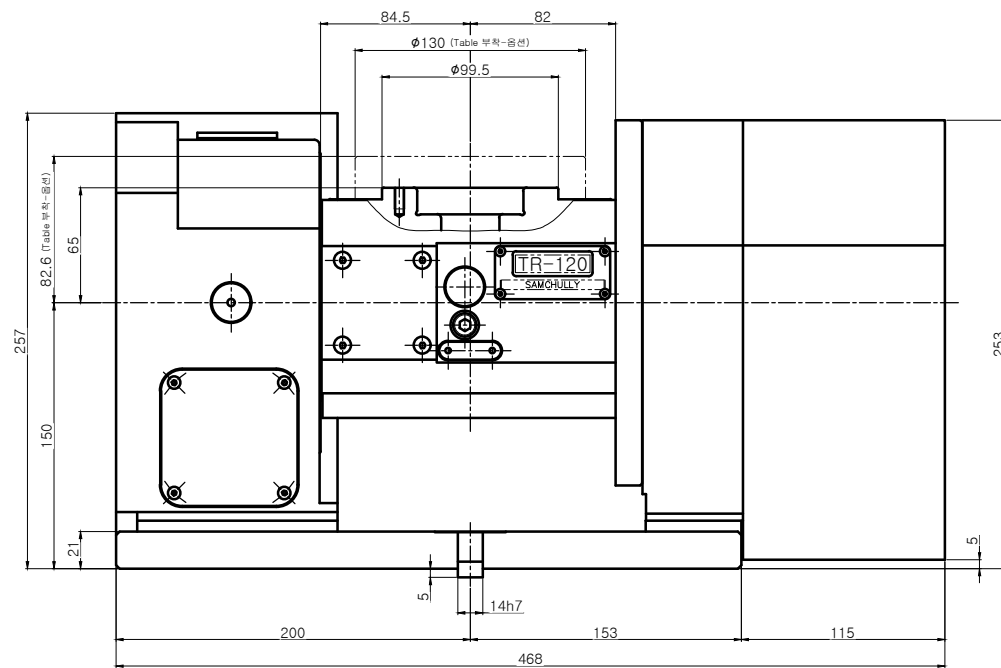
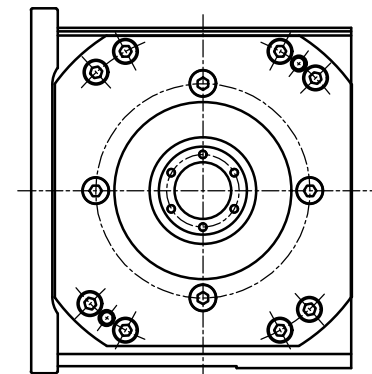

TITLE	Nc Rotary Table	PART NAME	외 형 도
DRG. NO.	TR-120YY-S01-00	USER	-
CODE NO.	-	DEPARTMENT	Research & Development
DATE	2009. 10. 10	DESIGNED	-
SCALE	1:1	APPROVED	-
	Approved	Checked	Designed